

Rod/Piston Seal

Technical details

Metric

Inch

Operating conditions

Maximum Speed
Temperature Range
Maximum Pressure

Operating conditions and maximum extrusion gap are dependent on type of material used.

Maximum Extrusion Gap

For further information contact your local Hallite sales office.

Surface roughness

Dynamic Sealing Face Rod $\varnothing d_1$
Static Sealing Face Rod $\varnothing D_1$
Dynamic Sealing Face Piston $\varnothing d_1$
Static Sealing Face Piston $\varnothing D_1$
Static Housing Faces L_1

μmRa	μmRt	μinCLA	μinRMS
0.1 < > 0.4	4 max	4 < > 16	5 < > 18
1.6 max	10 max	63 max	70 max
0.1 < > 0.4	4 max	4 < > 16	5 < > 18
1.6 max	10 max	63 max	70 max
3.2 max	16 max	125 max	140 max

Chamfers & Radii

Groove Section $\leq S$ in
Min Chamfer C in
Max Fillet Rad r_1 in
Max Fillet Rad r_2 in

0.125	0.187	0.250	0.312	0.375	0.500	0.625
0.093	0.093	0.125	0.156	0.187	0.187	0.217
0.008	0.008	0.016	0.032	0.032	0.032	0.047
0.016	0.016	0.032	0.047	0.047	0.047	0.062

Tolerances

Please refer to specified tolerances on the Hallite 500 Series details

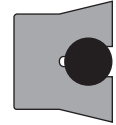

OL

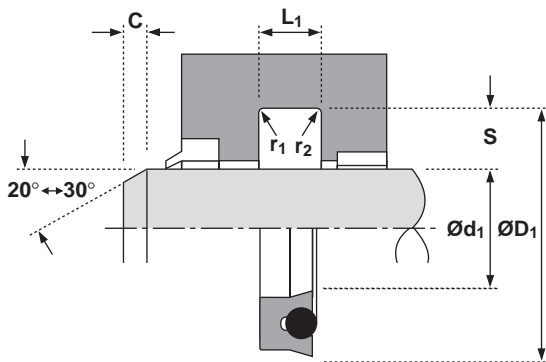

Design

The O ring Loaded Lip Seal (OL) is a molded seal with medium unit loading that offers good wear and contamination resistance. It is available in many elastomer (rubber) compounds.

Features

- Available in high temperature HNBR and genuine viton. Available upon request.
- Good wear characteristics
- Contamination resistance

ORDERING INFORMATION

For further information contact your local Hallite sales office.

